

AUTOMATIC NET WEIGHT LIQUID FILLING MACHINES - AE SERIES

ELECTRONIC NET WEIGHT FILLING FOR 1 GALLON TO 5 GALLON CONTAINERS



Ideal-Pak Model AE2-CFM Two Head Automatic Net Weight Liquid Filling Machine with DFS® Direct Fill System, Powered In-Feed Conveyor, 2 Gallon Crimper and 5 Gallon Crimper (optional).

PRODUCT OVERVIEW

The Ideal-Pak **PREMIER** Line delivers the highest of levels of automation and precision filling performance in a full-featured package. Improve productivity with automatic PLC-controlled filling, ladders, conveyor systems, and closers for hands-free operation. All Premier Line filling systems feature a large, color touch screen HMI with recipe storage, SPC with check-weigh data logging, and Ethernet connectivity for fast machine setup, real time filling performance tracking and remote machine performance tracking.

STANDARD PRODUCT FEATURES

- Fill by Weight (Electronic Net Weight Filling).
- 1 Gallon Through 5 Gallon Containers.
- Large 12" Color HMI with Touch Pad Interface.
- Clean Two Stage Conveyor Design.
- Precision Made Plug Nozzles For Consistent Fills and Easy Disassembly and Clean Up.
- No Lid Sensor.
- Patented Flush-Fill Cart System.
- Patented Interchangeable Fill Cart (Ideal-Pak DFS® Direct Fill System or Manifold Fill Cart).
- Permanent Lubrication.
- Rice Lake Weight Controller.
- Rigid Steel Frame Construction.

* Configurations available to fill pint, quart, & gallon containers.

CONTAINER SIZE

Small Containers		
1/2 Pint	•	Pails
Pints		Kegs
Quarts		Drums
• Gallons		Totes

INDUSTRIES SERVED

Paints & Coatings	
Chemicals	
Lubricants	
Food & Beverage	

ABOUT IDEAL-PAK

Ideal-Pak Liquid Filling Machines are designed to increase your yields, productivity and efficiency. Choose from Automatic to Semi-Automatic or Manual Configurations to fill small containers up to drums and totes. Ideal-Pak customers are in the paint and coatings, lubricants, chemicals and food & beverage industries. Ideal-Pak is also your first source for a wide variety of closing machines, lid placers and precision nozzles, plus parts and service, (including Neupak).

May be covered by one or more of the following U.S. Patents: #5,505,233, #5,823,406, #6,148,877, #6,595,250



Automatic Electronic Net Weight Liquid Filling Machine

MACHINE SPECIFICATIONS

Electrical	460 VAC, 3 Ø, 60 Hz
Air (per head)	60 SCFM @ 80 PSI (Clean Dry Air) w/pump
Speed (CPM)	Estimated Range*
1 Gallon	14 - 18
2 Gallon	10 - 14
5 Gallon	6 - 10
Accuracy: To Within $\pm .10$ lbs	
*Estimated average range for open top containers. Fill rates will vary depending on container size, container shape, fill opening, accuracy required, product supply, as well as individual product characteristics and operation mode.	

OPTIONS

- Additional Mobile Filling Carts.
- Explosion Proof Machine Upgrade (Class 1, Div 1).
- Flush Trough for Remote Fill Cart Cleaning.
- Glycol Pumps.
- Hand Capper (pneumatic).
- Ideal Pak's Exclusive Direct Fill System DFS® Fill Carts.
- In-feed and Exit Conveyors (Gravity Roller or Powered).
- Lid Placers.
- Nitrogen Purge Controls.
- Pump Controls.
- Roller Closers, Crimper Closers or Press Plate (burper) Closers.
- Rotary In-Feed or Accumulation Tables.
- Sanitary Contact Parts.
- Spare Parts Kits.
- Top Fill, Inside Fill or Bottom Up Filling.
- Various Nozzle Configurations; Cone, Plug, and Probe.
- Zinc Plated Carbon Steel, Stainless Steel or Epoxy Coated Paint Frame.

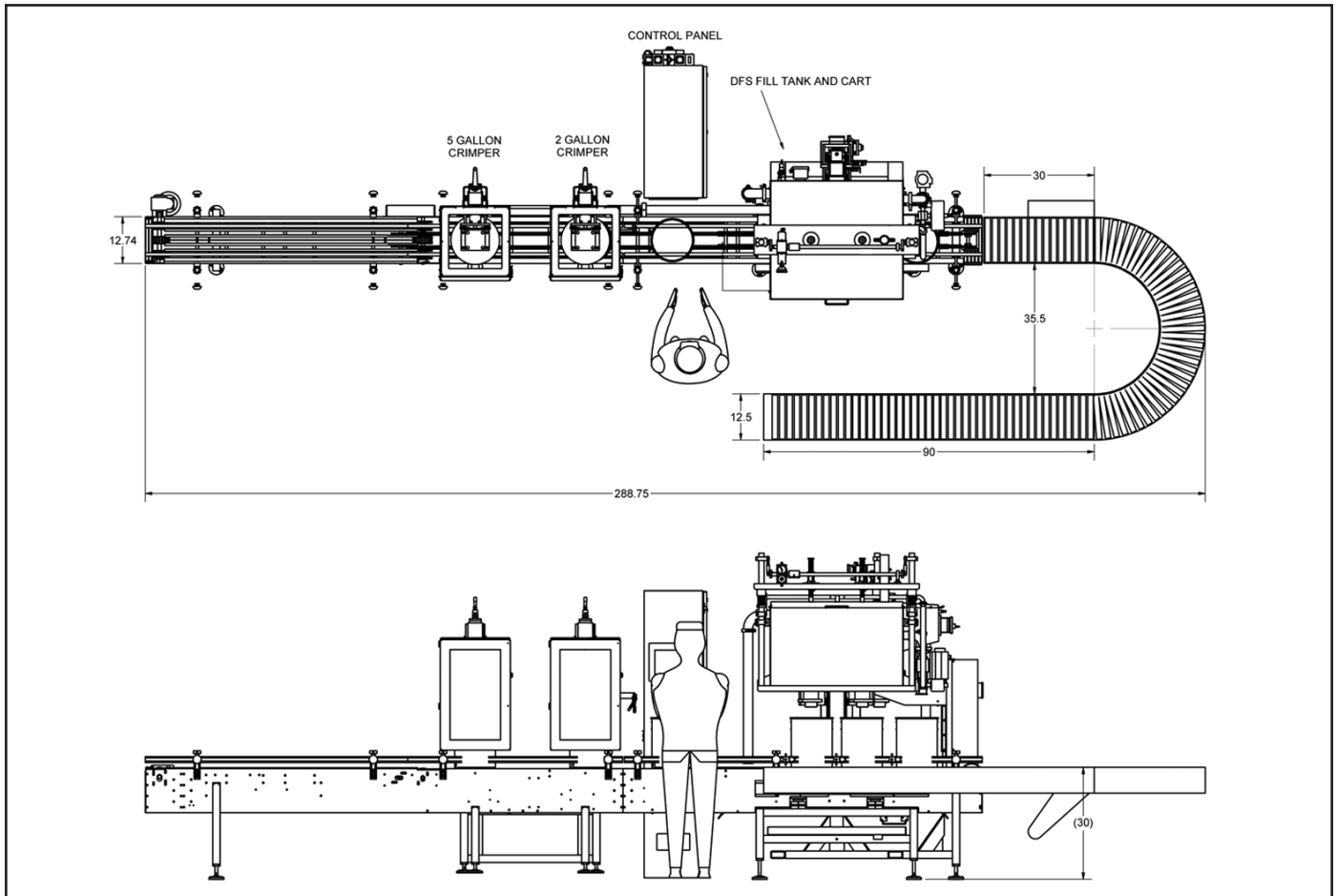

AE2-CFM Rev. 12-2015 Subject to changes and modifications without notice.
May be covered by one or more of the following U.S. Patents: #5,505,233, #5,823,406, #6,148,877, #6,595,250

